

## SMCE-1210

### FEATURES

- Surface mount ceramic enclosures
- High reliability seam welded package
- Ultra-light weight and ultra-miniature size
- Wide frequency range
- RoHS Compliant and Pb Free

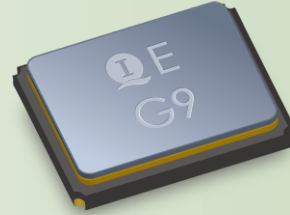

Electrical Specifications		
Parameters	Symbol	Specifications
Nominal Frequency Range 标称频率范围	$f_0$	24.0MHz ~ 100.0MHz
Frequency Tolerance, Ta=25°C ± 3°C 常温频率偏差	$\Delta f/f$	±10ppm, ±20ppm
Load Capacitance 负载电容	$C_L$	6pF or specify
Frequency Tolerance over Operating Temperature Range 频率温度特性	$\Delta f/f$	±10ppm, ±20ppm or specify
Operating Temperature Range 工作温度	$T_{OPR}$	-20°C ~ +70°C, -40°C ~ +85°C or specify
Storage Temperature Range 储存温度	$T_{STG}$	-55°C ~ +125°C
Drive Level 激励功率	DL	10µW Typ.
Shunt Capacitance 静态电容	$C_0$	2pF Max.
Insulation Resistance 绝缘电阻	IR	500MΩ Min.
Aging 老化率	$\Delta f_A$	±3ppm/Year Max.

Equivalent Series Resistance (ESR) 串联谐振阻抗		
Frequency Range	$24 < f_0 \leq 30$	$30 < f_0 \leq 60$
ESR	180Ω Max.	120Ω Max.

Please consult our sales representatives for other specifications. 如对其他规格查询, 请与我司销售人员联系。

### Dimensions

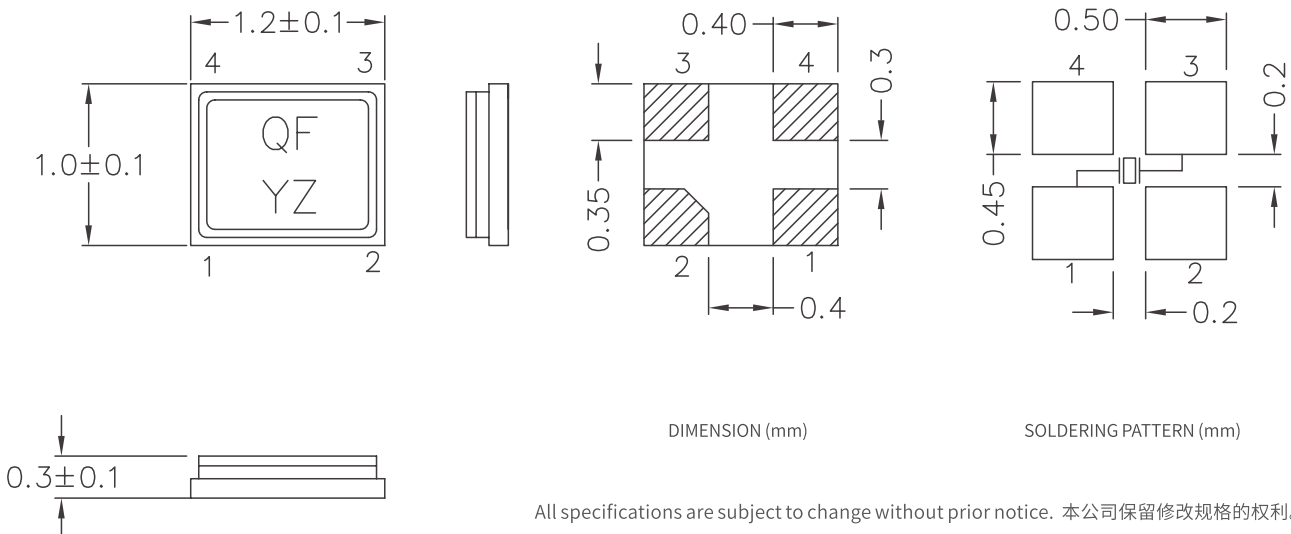

All specifications are subject to change without prior notice. 本公司保留修改规格的权利。